











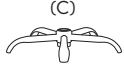

INCLUDED PARTS

Wheels 5 pcs	(A)	
Collar 1 pcs	(B)	
Base 1 pcs	(C)	
Gas Cylinder 1 pcs	(D)	
Lift Release Tray 1 pcs	(E)	
Chair Back 1 pcs	(F)	
Left Arm Rest 1 pcs	(G)	
Right Arm Rest 1 pcs	(H)	
Seat 1 pcs	(I)	
6 x 20mm Bolts 4 pcs	(J)	
6 x 25mm Bolts 6 pcs	(K)	
Washers 4 pcs	(L)	
Allen Wrench 1 pcs	(M)	

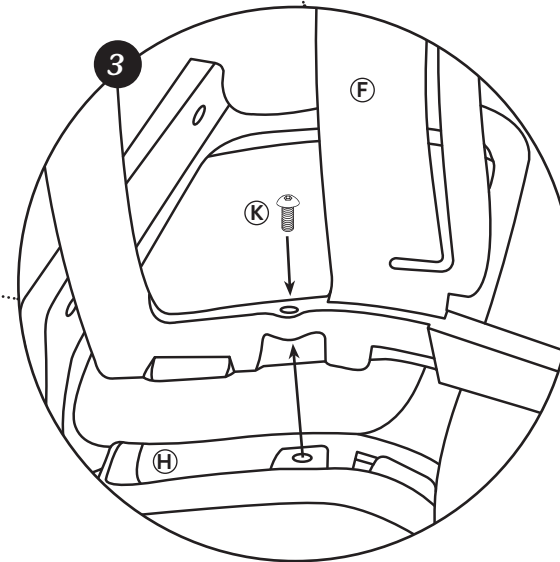
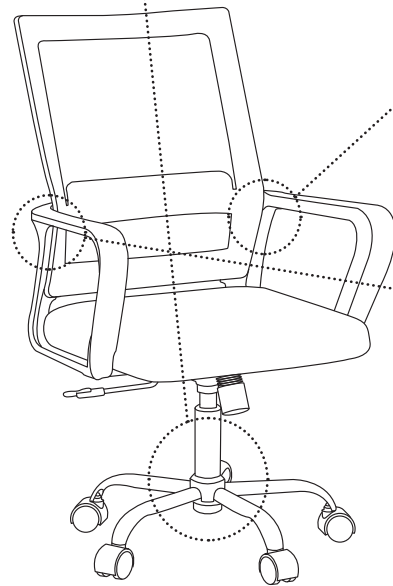
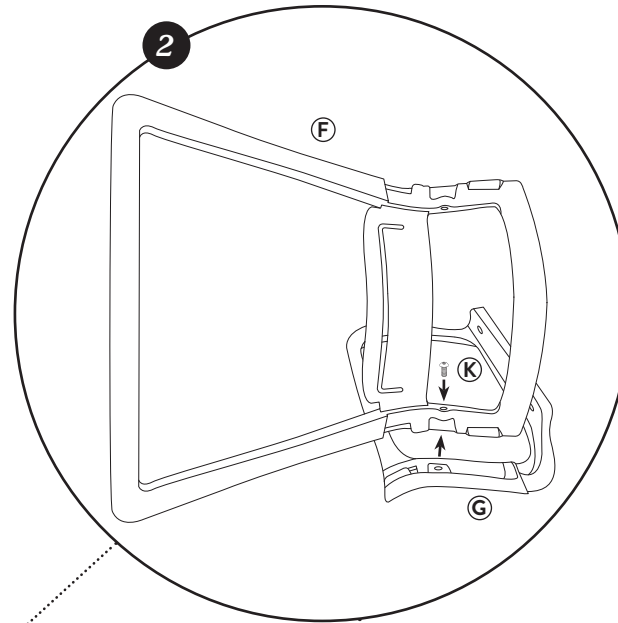
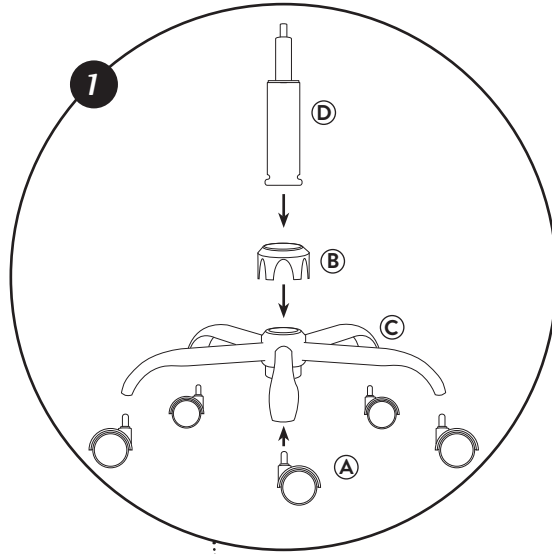

1. Insert the Wheels (A) into each of the five legs on the Base (C), then place the Collar (B) over the Base (C), and finally insert the Gas Cylinder (D) into the center of the Base (C).
2. Lay the Left Arm Rest (G) on its side with the threaded hole facing upwards, align the Chair Back (F) with the tabs on the armrest, and secure it using one 6 x 25mm Bolt (K), tightening with the Allen Wrench (M).
3. Repeat Step 2 with the Right Arm Rest (H) to complete the Chair Back.

CONTINUE TO NEXT PAGE →



Desk Chair Assembly













SKUS: 4790000

NEED HELP?

1-800-444-8444

warranty@rizehome.com

INCLUDED PARTS

- Wheels
5 pcs 
- Collar
1 pcs 
- Base
1 pcs 
- Gas Cylinder
1 pcs 
- Lift Release Tray
1 pcs 
- Chair Back
1 pcs 
- Left Arm Rest
1 pcs 
- Right Arm Rest
1 pcs 
- Seat
1 pcs 
- 6 x 20mm Bolts
4 pcs 
- 6 x 25mm Bolts
6 pcs 
- Washers
4 pcs 
- Allen Wrench
1 pcs 

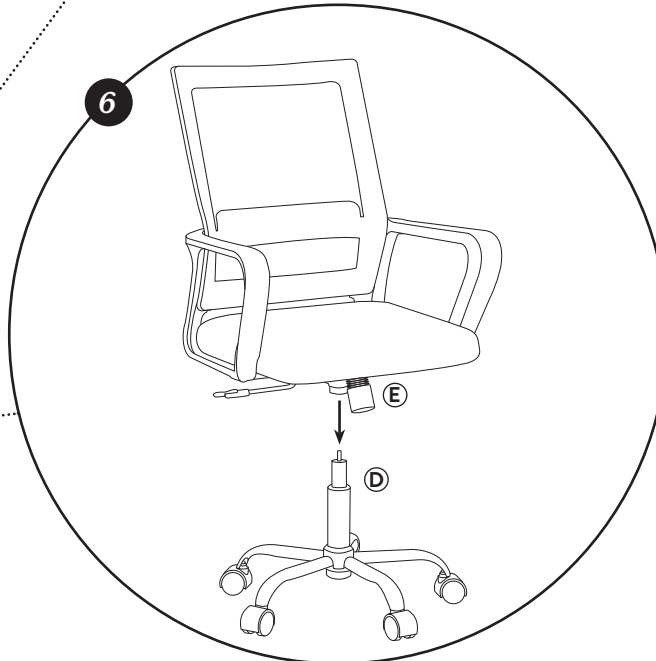
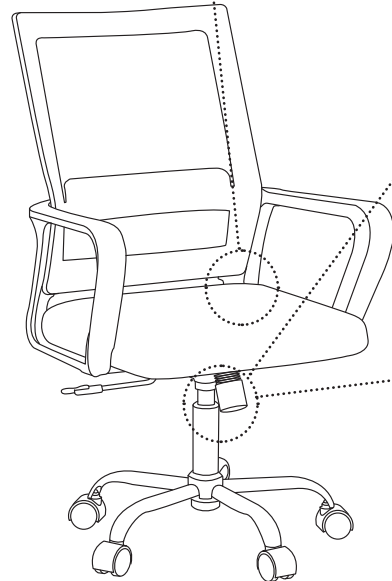
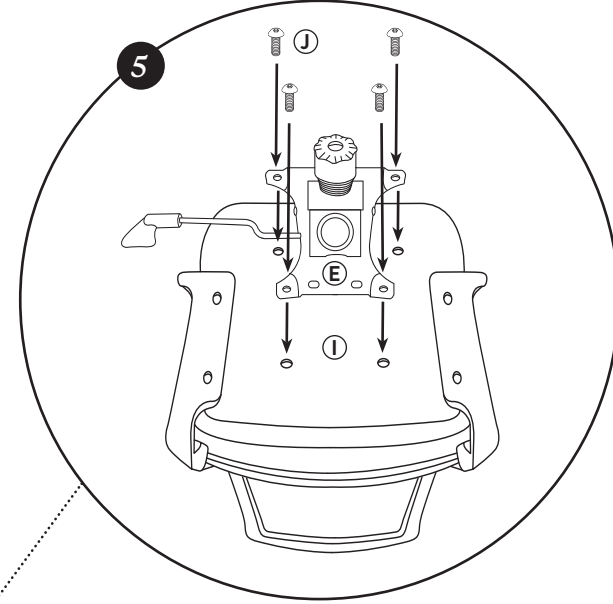
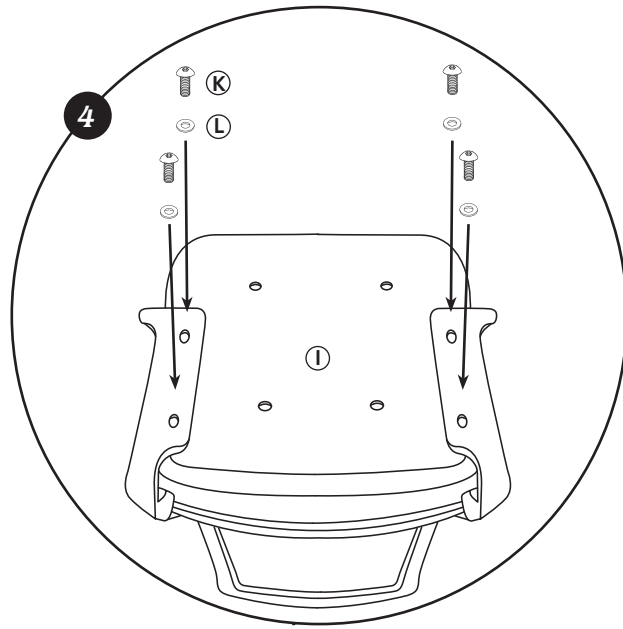

4. Align the Seat (I) with the assembled Arm Rests and Chair Back. Secure it by inserting four 6 x 25mm Bolts (K) followed by Washers (L) through the slotted holes in the lower armrests using the Allen Wrench (M).
5. Position the Lift Release Tray (E) on the bottom of the Seat (I), aligning the "FRONT" marking with the front of the seat. Secure with four 6 x 20mm Bolts (J) using the Allen Wrench (M).
6. Place the assembled Seat onto the Gas Cylinder (D) and press down firmly to secure. The Lift Release Tray (E) will lock onto the Gas Cylinder (D) once fully seated.

Your desk chair is now fully assembled!